

- 316 STAINLESS STEEL - ASTM A351
- CARBON STEEL - AST A216 WCB
- ALLOY 20 - ASTM A351 CN7M
- LIVE LOADED STEM
- CHEVRON STEM PACKING
- FULL PORT DESIGN
- 4 SEATS DESIGN
- TRUNNION SUPPORT BALL (3" & 4")
- LOCKABLE HANDLE
- ISO 5211 DIRECT MOUNT MOUNTING PAD
- MC PAD ELEVATED PAD ALLOWED TO ADJUST GLAND PACKAGING FLANGE WHILE VALVE IS IN SERVICE WITHOUT REMOVING ACTUATOR OR HANDLE

Series 17

1/2"-2"

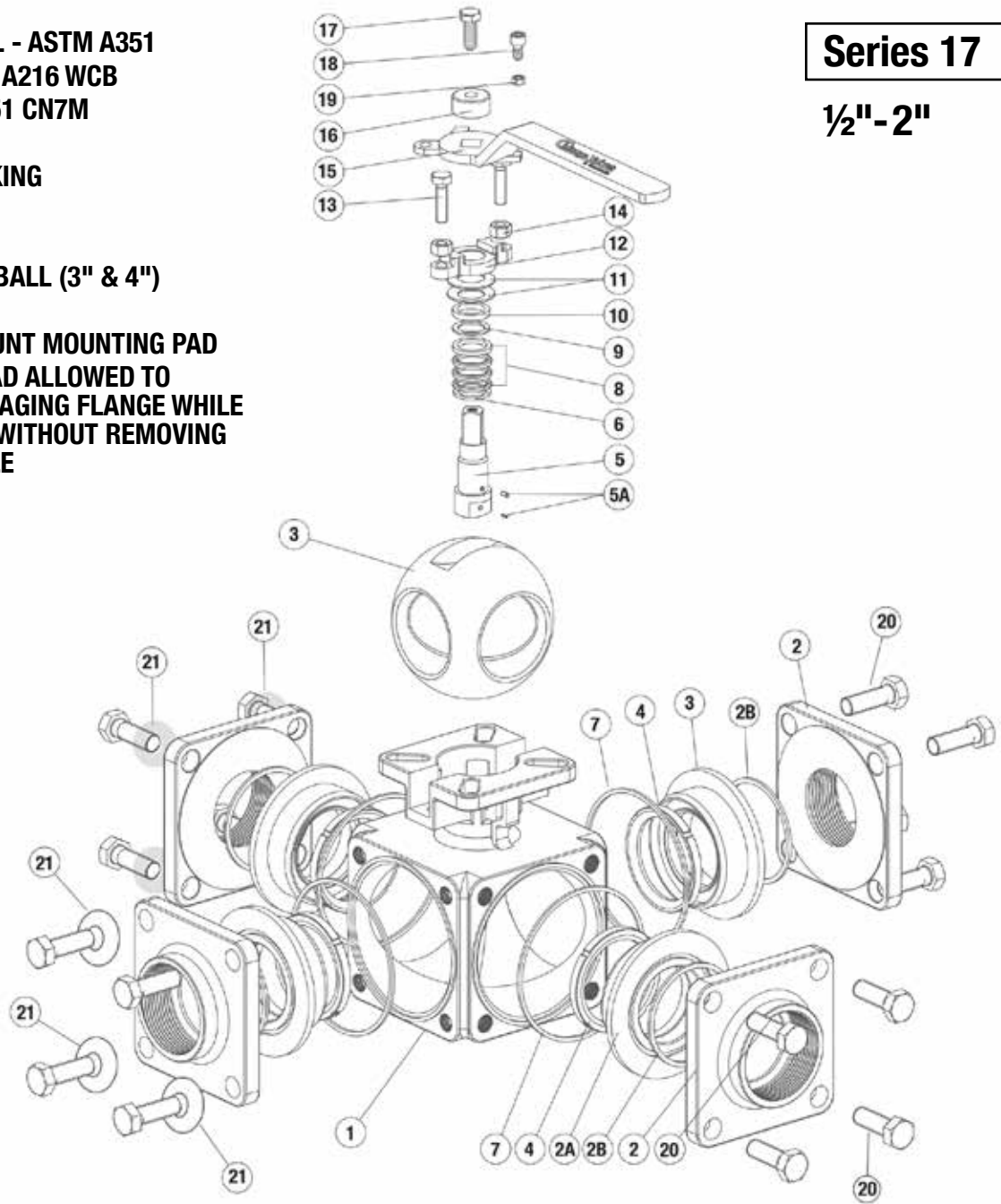

PARTS & MATERIAL

PART NO	PART NAME	QTY	MATERIAL
1	BODY	1	CARBON STEEL ASTM A216 WCB 316 STAINLESS STEEL ASTM A351 CF8M
2	ENDS	4	CARBON STEEL ASTM A216 WCB 316 STAINLESS STEEL ASTM A351 CF8M
2A	SEAT SUPPORT (USE IN THREADED & SOCKET WELD)	4	316 STAINLESS STEEL ASTM A351 CF8M
2B	SEAT SUPPORT SEAL	4	PTFE
3	BALL	1	316 STAINLESS STEEL
4	SEAT	4	TFM / XN
5	STEM	1	316 STAINLESS STEEL
5A	ANTI-STATIC DEVICE	2	316 STAINLESS STEEL HARD DRAWN SST
6	LOWER THRUST WASHER	1	RTFE
7	BODY SEAL	4	PTFE / GRAPHITE
8	STEM PACKING	1 SET	TFM / XN

PARTS & MATERIAL

PART NO	PART NAME	QTY	MATERIAL
9	THRUST WASHER	1	RTFE
10	GLAND RING	1	300 SERIES STAINLESS STEEL
11	BELLEVILLE WASHER	2	SUS 304 CSP
12	GLAND FLANGE	1	300 SERIES STAINLESS STEEL
13	GLAND FLANGE BOLT	2	300 SERIES STAINLESS STEEL
14	GLAND FLANGE NUT	2	300 SERIES STAINLESS STEEL
15	HANDLE	1	300 SERIES STAINLESS STEEL
16	STEM CAP	1	300 SERIES STAINLESS STEEL
17	STEM CAP BOLT	1	300 SERIES STAINLESS STEEL
18	STOP BOLT	1	A193 B8
19	STOP NUT	1	A193 B8
20	BODY BOLT	16	A193 B8
21	BODY BOLT WASHER	16	A193 B8

Series 17

1/2"-4"

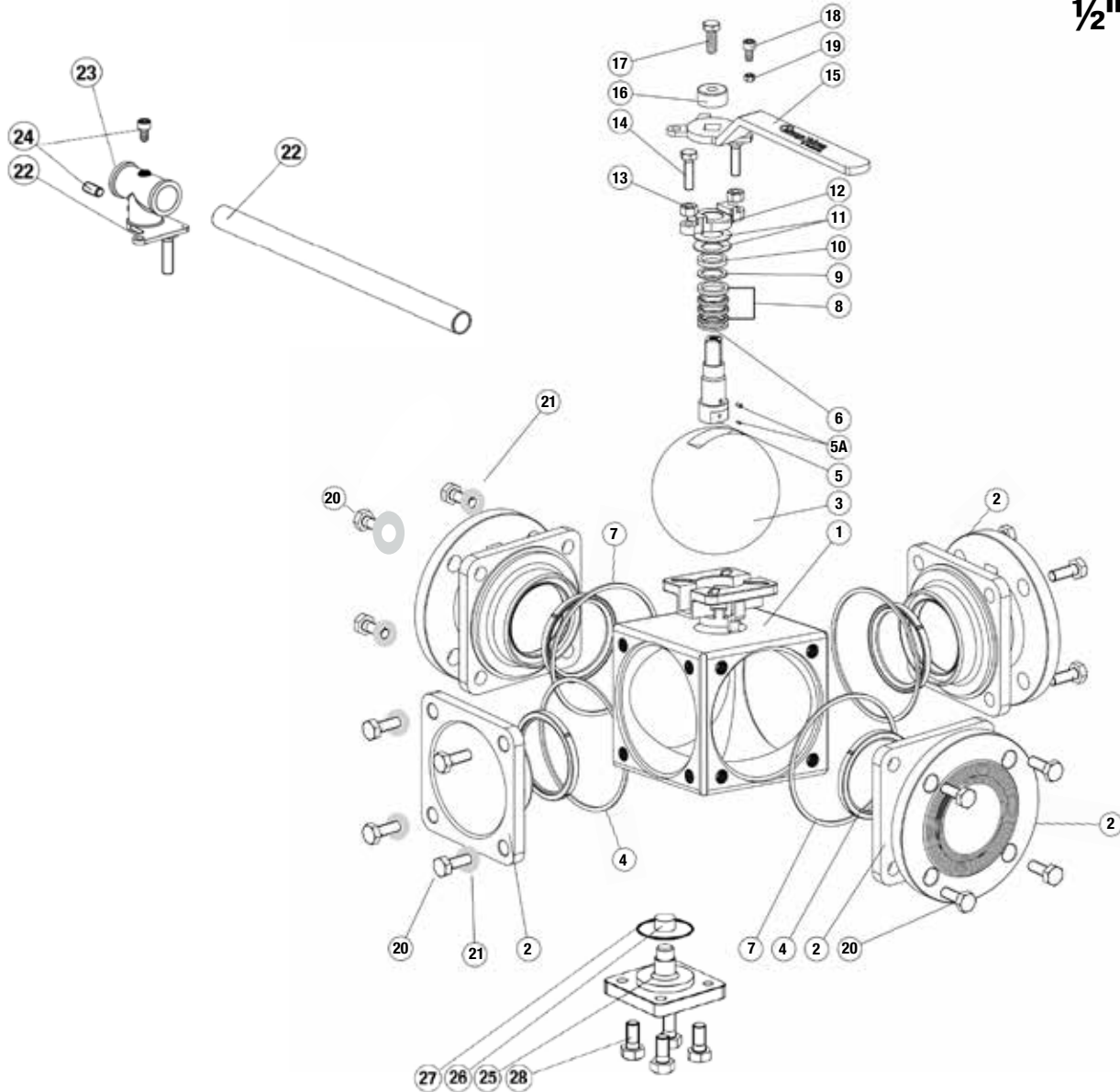

PARTS & MATERIAL

PART NO	PART NAME	QTY	MATERIAL
1	BODY	1	CARBON STEEL ASTM A216 WCB 316 STAINLESS STEEL ASTM A351 CF8M
2	ENDS	4	CARBON STEEL ASTM A216 WCB 316 STAINLESS STEEL ASTM A351 CF8M
3	BALL	1	316 STAINLESS STEEL
4	SEAT	4	TFM / XN
5	STEM	1	316 STAINLESS STEEL
5A	ANTI-STATIC DEVICE	2	316 STAINLESS STEEL HARD DRAWN SST*
6	LOWER THRUSH WASHER	1	RTFE
7	BODY SEAL	4	PTFE / GRAPHITE
8	STEM PACKING	1 SET	TFM / XN
9	THRUST WASHER	1	RTFE
10	GLAND	1	300 SERIES STAINLESS STEEL
11	BELLEVILLE WASHER	2	SUS 304-CSP
12	GLAND FLANGE	1	300 SERIES STAINLESS STEEL
13	NUT	2	300 SERIES STAINLESS STEEL

PARTS & MATERIAL

PART NO	PART NAME	QTY	MATERIAL
14	GLAND BOLT	2	300 SERIES STAINLESS STEEL
15	HANDLE	1	300 SERIES STAINLESS STEEL
16	STEM CAP	1	300 SERIES STAINLESS STEEL
17	STEM CAP BOLT	1	300 SERIES STAINLESS STEEL
18	STOP BOLT	1	A193- B8
19	STOP NUT	1	A193-B8
20	BODY BOLT	16	A193-B8
21	BODY BOLT WASHER	16	A193-B8
22	HANDLE/PIPE	1	304 STAINLESS STEEL
23	HANDLE T	1	304 STAINLESS STEEL
24	HANDLE NUT	1	A193-B8
25	BALL SUPPORT FLANGE	1	316 STAINLESS STEEL 3" & 4"
26	BUSHING	1	PTFE
27	SEAL	1	PTFE
28	BOLT	4	A193-B8

* Stainless Steel

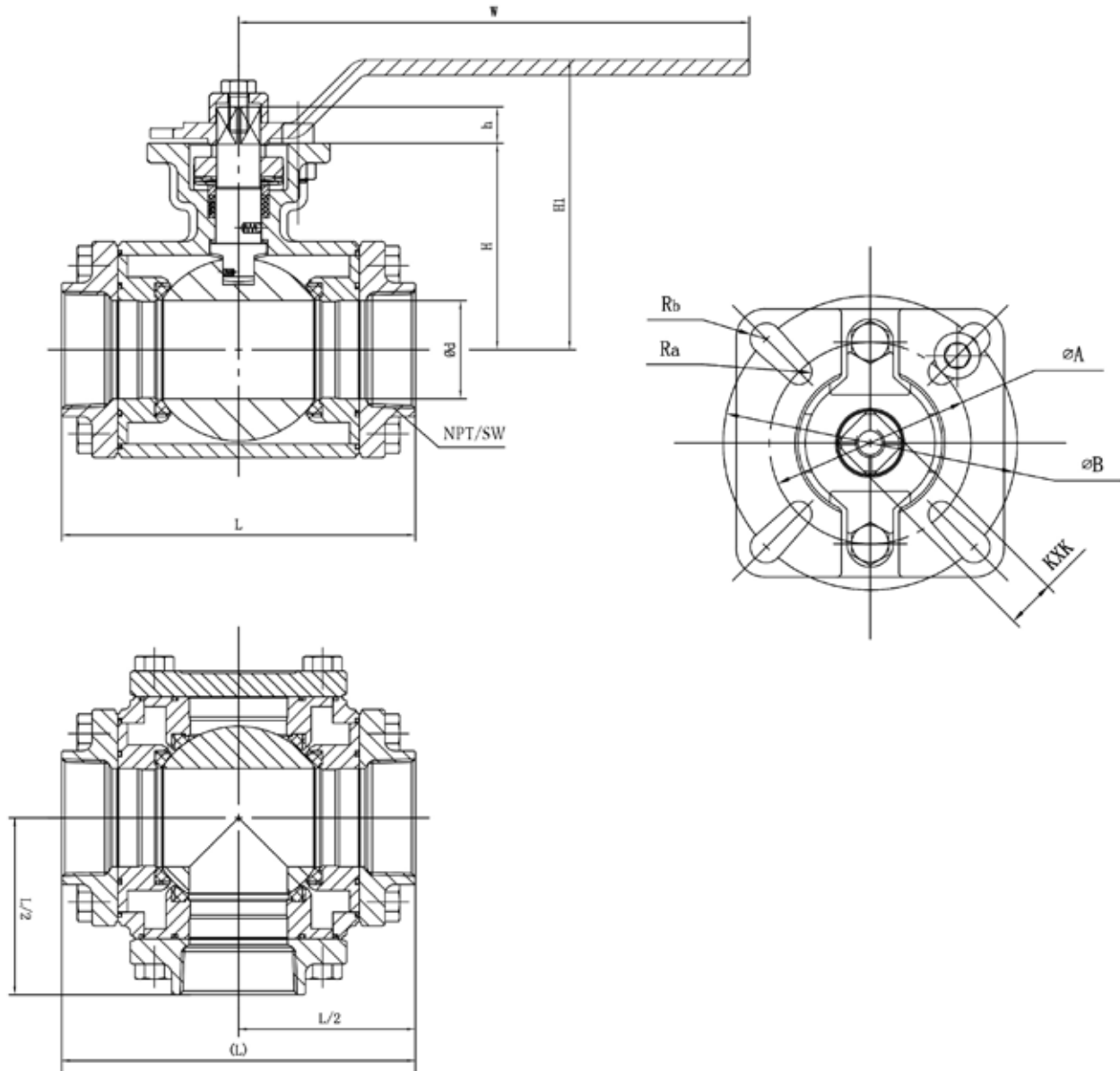

DIMENSIONS (INCHES) THREADED & SOCKET WELD

NOMINAL DIAMETER	L	d	H	h	H1	W	Ra	Rb	A	B	KXK
1/2"	4.33	0.59	2.36	0.43	3.7	7.09	0.12	0.14	F04	F05	0.43X0.43
3/4"	4.33	0.78	2.36	0.43	3.7	7.09	0.12	0.14	F04	F05	0.43X0.43
1"	5.04	0.98	2.50	0.43	3.85	7.09	0.12	0.14	F04	F05	0.43X0.43
1 1/2"	6.15	1.50	3.23	0.55	4.72	8.27	0.14	0.18	F05	F07	0.55X0.55
2"	7.09	1.97	4.13	0.67	5.79	10.23	0.18	0.22	F07	F10	0.67X0.67

Series 17

1/2"-4"

CLASS 150#

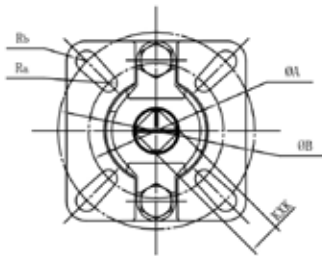
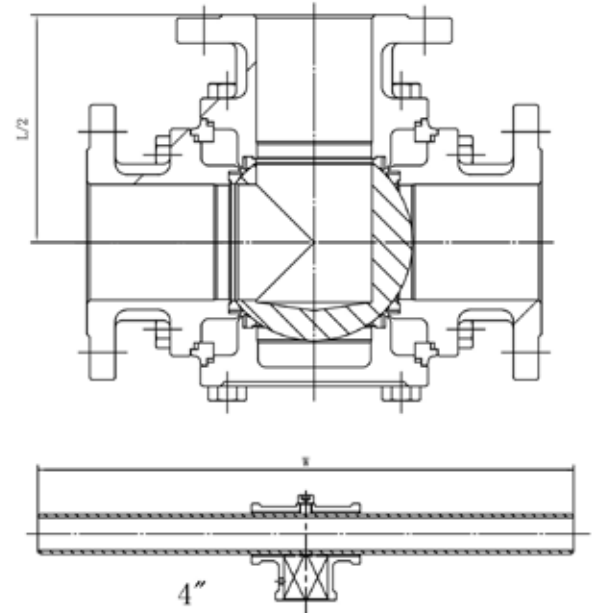
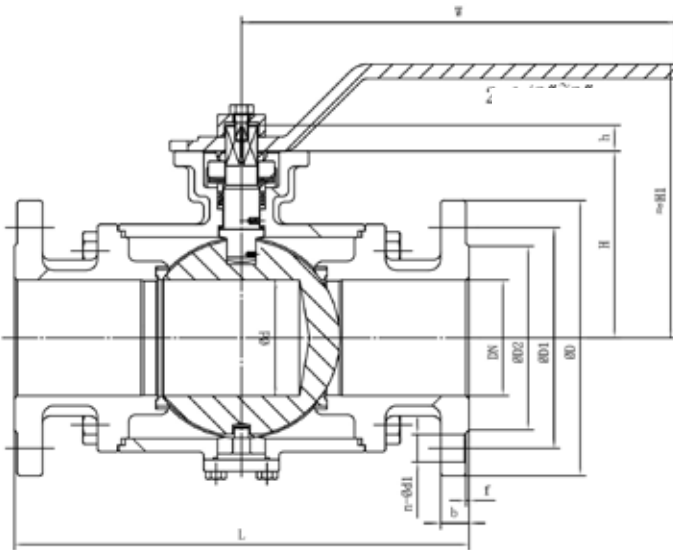

DIMENSIONS (INCHES) FLANGED CLASS 150#

NOMINAL DIAMETER	L	d	D2	D1	D	b	f	n-0d1	H	h	Ra	Rb	A	B	KXK	W	H1
1/2"	6.30	0.59	1.38	2.37	3.54	0.39	0.08	4-00.63	2.36	0.35	0.12	0.14	F04	F05	0.43X0.43	5.91	3.30
3/4"	6.50	0.78	1.69	2.76	3.94	0.41	0.08	4-00.63	2.36	0.35	0.12	0.14	F04	F05	0.43X0.43	5.91	3.30
1"	7.09	0.98	2.01	3.13	4.33	0.41	0.08	4-00.63	2.48	0.43	0.12	0.14	F04	F05	0.43X0.43	6.69	3.94
1 1/2"	8.27	1.50	2.87	3.87	4.92	0.50	0.08	4-00.63	3.23	0.55	0.14	0.18	F05	F07	0.55X0.55	7.87	5.04
2"	9.84	1.97	3.62	4.75	5.91	0.56	0.08	4-00.75	4.13	0.67	0.18	0.22	F07	F10	0.67X0.67	7.87	5.67
2 1/2"	11.02	2.56	4.13	5.50	7.09	0.63	0.08	4-00.75	4.72	0.67	0.18	0.22	F07	F10	0.67X0.67	11.81	6.38
3"	12.32	3.15	5.00	6.00	7.48	0.69	0.08	4-00.75	5.08	0.67	0.18	0.22	F07	F10	0.67X0.67	11.81	6.77
4"	14.96	3.94	6.18	7.50	9.06	0.88	0.08	8-00.75	6.14	0.98	0.22	0.26	F10	F12	0.87X0.87	23.62	9.84

Series 17

1/2"-4"

CLASS 300#

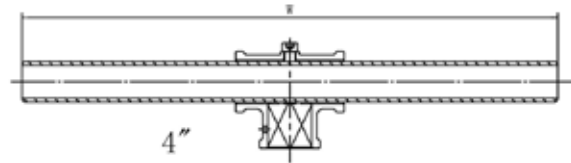
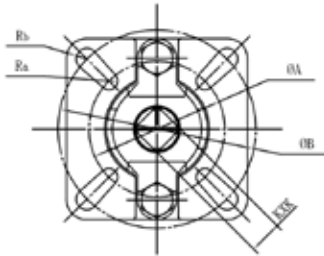
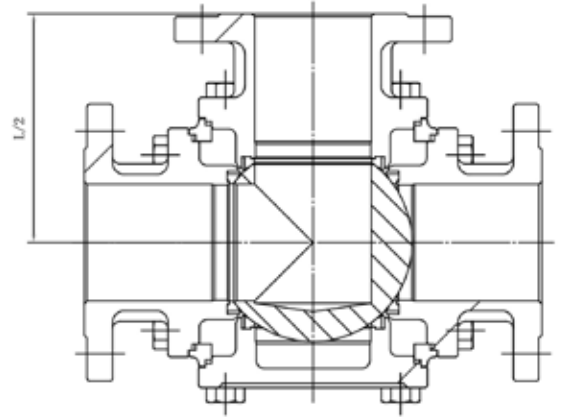
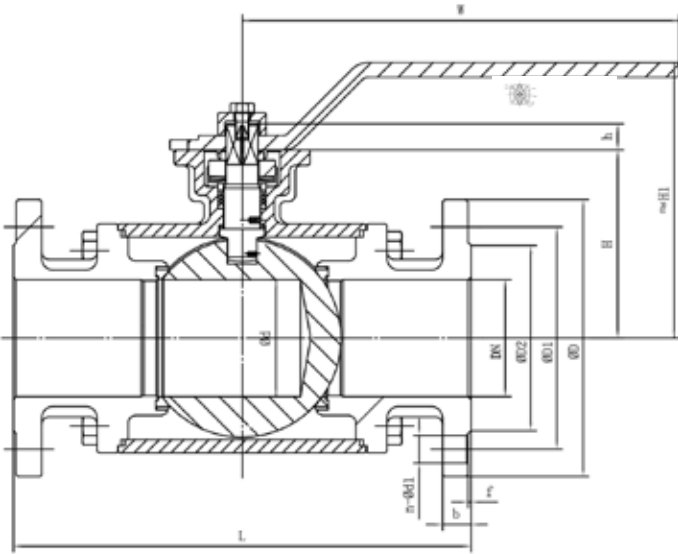

DIMENSIONS (INCHES) FLANGED CLASS 300#

NOMINAL DIAMETER	L	d	D2	D1	D	b	f	n-0d1	H	h	Ra	Rb	A	B	KXK	W	H1
1/2"	6.50	0.59	1.38	2.63	3.74	0.50	0.08	4-00.63	2.36	0.35	0.12	0.14	F04	F05	0.43X0.43	5.91	3.30
3/4"	6.89	0.78	1.69	3.25	4.53	0.56	0.08	4-00.75	2.36	0.35	0.12	0.14	F04	F05	0.43X0.43	5.91	3.30
1"	7.68	0.98	2.01	3.50	4.92	0.63	0.08	4-00.75	2.48	0.43	0.12	0.14	F04	F05	0.43X0.43	6.69	3.94
1 1/2"	8.86	1.50	2.87	4.50	6.10	0.75	0.08	4-00.75	3.23	0.55	0.14	0.18	F05	F07	0.55X0.55	7.87	5.04
2"	10.43	1.97	3.62	5.00	6.50	0.81	0.08	8-00.87	4.13	0.67	0.18	0.22	F07	F10	0.67X0.67	7.87	5.67
2 1/2"	11.81	2.56	4.13	5.87	7.48	0.94	0.08	8-00.87	4.72	0.67	0.18	0.22	F07	F10	0.67X0.67	11.81	6.38
3"	13.19	3.15	5.00	6.63	8.27	1.06	0.08	8-00.87	5.08	0.67	0.18	0.22	F07	F10	0.67X0.67	11.81	6.77
4"	15.75	3.94	6.18	7.87	10.04	1.19	0.08	8-00.87	6.14	0.98	0.22	0.26	F10	F12	0.87X0.87	23.62	9.84

PRESSURE-TEMPERATURE RATINGS SERIES 17

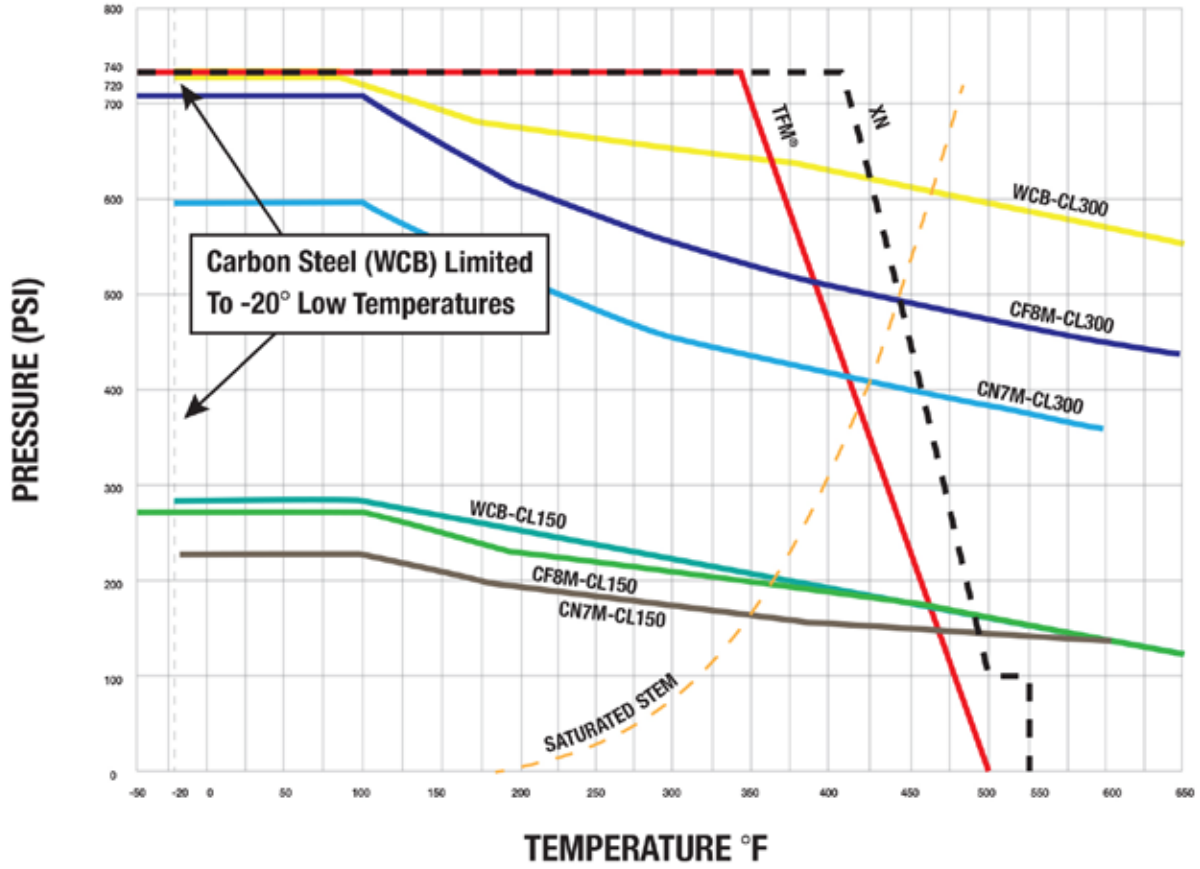

CV DATA

SIZE	T PORT	L PORT	LLCv	180° DEGREE-CV
1/2"	13	8	8	10
3/4"	22	13	12	14
1"	35	21	22	25
1 1/2"	85	49	46	52
2"	160	93	95	105
2 1/2"	267	154	137	150
3"	365	211	220	250
4"	649	375	366	420

WEIGHT (LBS)

SIZE	BODY	SOCKET WELD & THREADED END	FLANGED END 150LBS	FLANGED END 300LBS	BLIND END
1/2"	1.69	0.82	2.54	1.65	0.40
3/4"	1.69	0.82	3.11	2.03	0.40
1"	2.34	0.84	4.12	2.71	0.84
1 1/2"	4.29	1.80	7.74	5.93	2.25
2"	8.08	3.15	10.26	7.78	3.57
2 1/2"	12.75	4.01	15.94	12.02	4.74
3"	19.31	5.14	21.66	15.60	8.50
4"	26.74	7.19	33.33	25.49	10.10

FLOW CHART

T-Port 90°

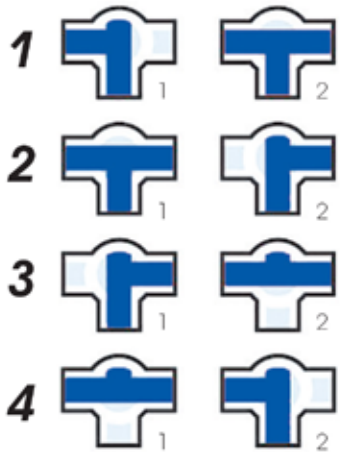

T-Port 180°

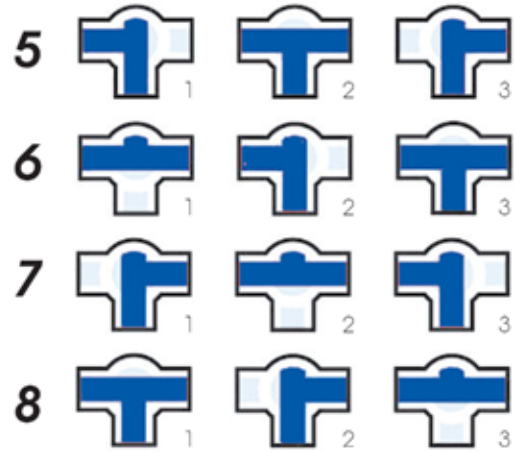

L-Port 90°



L-Port 180°



LL-Port 90°



L-Port 180°



T-Port 270°



4-Way 90°



HOW TO ORDER

2"

Size

17

Series

6

Body

6

Ball & Stem

M

Seat

T

Stem Packing

T

Seal

6

Ends

4

Flow Plan

1

End Cap Type

SIZE	
1/2"	2"
3/4"	2 1/2"
1"	3"
1 1/2"	4"

SERIES
17

BODY	
4	Carbon Steel
6	316 Stainless Steel

BALL & STEM	
6	316 Stainless Steel

SEAT	
M	TFM
X	XN*
C	Cavity Fill TFM

STEM PACKING	
T	PTFE
X	XN*

*XN Carbon Fill TFM

SEAL	
T	PTFE
G	Graphite

ENDS	
4	Carbon Steel
6	316 Stainless Steel

FLOW PLAN	
1	8
2	9
3	10
4	11
5	12
6	13
7	14

END CAP TYPE	
1	150# RF Flange
3	300# RF Flange
4	Threaded Ends
5	Socket Weld
6	Butt Weld Sch, 10, 40, 80

Chicago Valves
& Controls



Toll-Free (833) 831-2312

Local (312) 637-3557

Fax: (312) 637-3543

E-Mail: sales@chicagovalves.com

www.chicagovalves.com

885 Cambridge Dr.

Elk Grove Village, Illinois 60007 U.S.A.